

Please read and save these instructions. Read carefully before attempting to assemble, install, operate or maintain the product described. Protect yourself and others by observing all safety information. Failure to comply with instructions could result in personal injury and/or property damage!



Easy Spray Guns



Table Of Contents

Description	1
General Safety Information	1-2
Setup	2-3
Needle/Nozzle Replacement	4
Preparation	5
Operation	5-8
Cleaning & Maintenance	8
Troubleshooting	8-10
Ordering Replacement Parts	11
Warranty	12

Description

High volume, low pressure (HVLV) paint sprayers are designed to deliver a fine finish with low overspray. The sprayer can be used to apply various acrylics, stains, sealers, lacquers, latexes, and primers. This unit can be used for painting cabinets, furniture, machinery, equipment, walls and trim work. Sprayers of this type are not recommended for automotive final coat. This portable unit is an ideal alternative to conventional spray guns. The Easy Spray's high transfer efficiency provides professional results with much less material waste and environmental contamination than other conventional spray painting systems.

Unpacking

When unpacking the sprayer, inspect carefully for any damage that may have occurred during transit. Make sure any

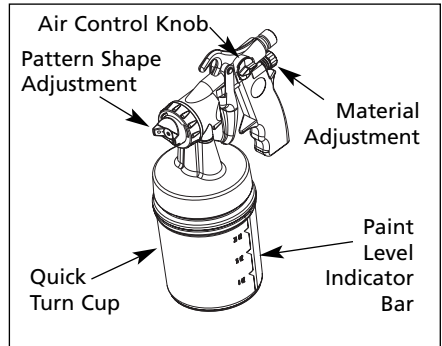

Spray Gun Features

loose fittings, bolts, etc., are tightened before putting sprayer into service. Each sprayer has been tested before shipment.

NOTE: The packing nut may need additional adjustment due to the packing material relaxing during shipment.

The fluid used for testing the sprayer has been drained, but some of this fluid will remain in the spray gun. This fluid should be flushed from the spray gun to prevent contamination of the coating material. Use a solvent compatible with the coating to be sprayed.

General Safety

⚠ DANGER *Danger indicates an imminent hazardous situation which, if not avoided, WILL result in death or serious injury.*

General Safety (Continued)

⚠ WARNING *Warning indicates a potentially hazardous situation which, if not avoided, COULD result in death or serious injury.*

⚠ CAUTION *Caution indicates a potentially hazardous situation which, if not avoided, MAY result in minor or moderate injury.*

⚠ NOTICE *Notice indicates important information, that if not followed, may cause damage to equipment.*

Read all instructions and safety precautions before operating the unit.



⚠ WARNING

Risk of fire or explosion! Solvent and paint fumes can explode or ignite, causing severe injury and property damage.



Do not use to spray HALOGENATED HYDROCARBONS. Paints and solvents containing halogenated hydrocarbons can react explosively with aluminum. Always check the product's label before using these materials in the unit.

Unit is not intended for spraying flammable materials.

Make sure the room is well-ventilated.

Avoid all ignition sources, such as static electricity sparks, open flames, hot objects, sparks from connecting and disconnecting power cords, and working light switches.

Follow the material and solvent manufacturers' safety precautions and warnings. Do not use liquids with flash points less than 100° F (38° C).

Do not carry TURBINE while spraying.

Keep the turbine at maximum distance from spraying area.

Static electricity can be produced by HVLP spraying. Make sure any electrically conductive object being sprayed is grounded to prevent static sparking. The sprayer is grounded through the electric cord. If an extension cord is necessary, the cord must be a grounded, 115 volt, three wire type cord.

Hazardous vapors: Paints, solvents, insecticides, and other materials may be harmful if inhaled causing severe nausea, fainting or poisoning.

Always wear a mask or respirator and eye protection when painting. Be certain mask or respirator will provide necessary protection against inhalation of harmful vapors.



NEVER point spray gun at any part of the body or at anyone else.

⚠ CAUTION

Tipping gun may cause clogs. Dried spray material also clogs pressure delivery tube and fittings. The spray gun will not function when clogged.

When not in use, be sure to disconnect hose and place gun on a solid, level surface, or in the gun storage area located in the housing, to avoid tipping

Set-Up

SPRAY GUN COMES ASSEMBLED

1. Unscrew cup

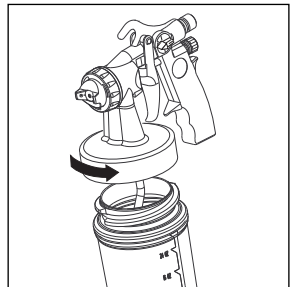

Set-Up (Continued)

2. Pour paint into cup.

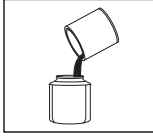

3. Insert viscosity stick into paint and stir. Lift stick out and compare drip to Figures A, B & C.

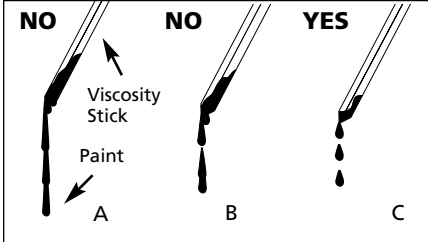

When paint drips from stick as shown in C, approximately 1 drip per second, paint is correctly thinned.

4. Check cup seal on inside of lid and make sure check valve is installed as shown.

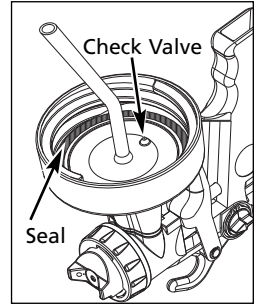

5. Screw cup onto gun.

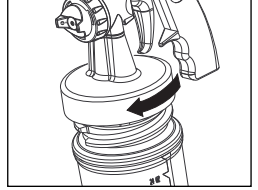

NEEDLE/NOZZLE INSTALLATION (IF NEEDED)

Note: After selecting correct needle and nozzle for painting use, store unused needle/nozzle in storage area of turbine

Needle/Nozzle identification and Needle Size/Material Usage

Thin (included with some models)

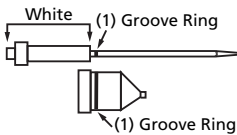

Stains
Polyurethanes
Sealers
Dyes

All-Purpose (Installed on all models)

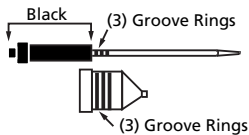

Latex
Enamels
Glazes
Acrylics
Oil-based Interior Paint

Thick (Optional Accessory)

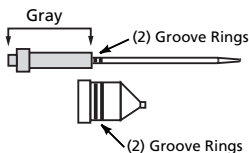

Primers
Heavy Latex
Oil-Based Exterior Paint

Needle/Nozzle Replacement (if needed)

Note: NEEDLE MUST BE REMOVED BEFORE NOZZLE.

1. Unscrew material control knob at rear of gun.

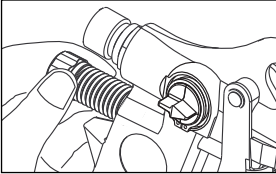

2. Pull trigger to push needle back.

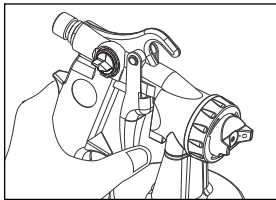

3. Fit wrench around needle sleeve and push out handle toward opening.

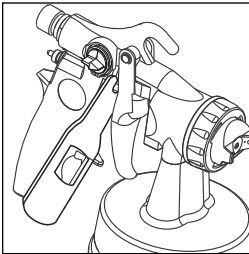

4. Use wrench to pull needle out.

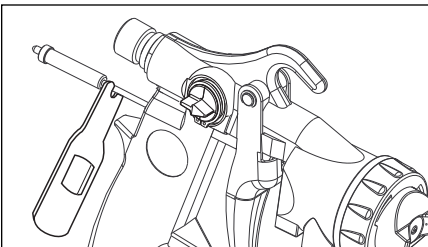

5. Unscrew retaining ring.

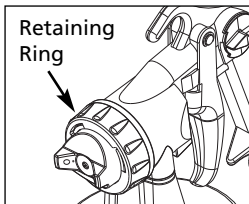

6. Remove air cap.

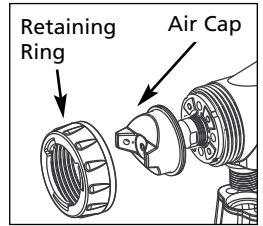

7. Use wrench to remove nozzle.

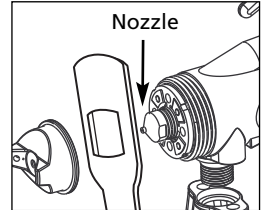

8. Screw new nozzle on.

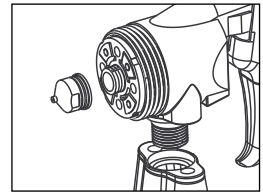

9. Replace air cap and screw retaining ring back on.

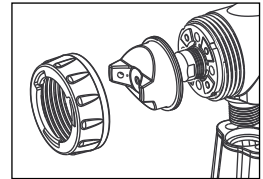

10. Insert needle to be used, and fit securely into hole.

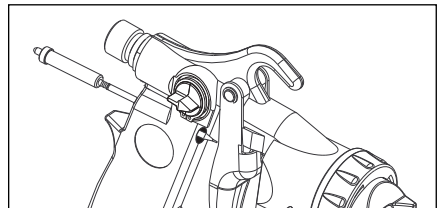

11. Replace material control knob.

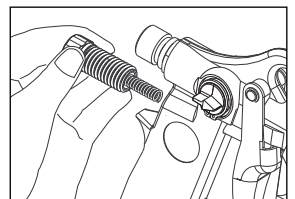

Preparation

Preparing the Paint

To prepare paint for the Easy Spray Gun, it must be stirred to an even consistency with a paint stirrer or clean dowel. Run the paint through a paint strainer like those included in the Easy Spray package, or the reusable strainer accessory, to remove any hardened paint particles or bristle remnants that might clog the sprayer.

Preparing the Surface

WALLS

Surface preparation is the key to achieving a smooth, seamless finish.

Begin by patching nail holes or cracks in the wall with drywall compound. Apply as directed and allow to dry. Sand for a smooth finish.

Wipe your walls and trim with a damp cloth to remove dirt, residue and debris.

FURNITURE

Do not paint furniture with plastic or vinyl veneer. Paint will not stick to these surfaces.

Remove cabinet doors, drawers and hardware (knobs, pulls and hinges).

For wood pieces only: If you plan to use new hardware after the piece has been painted, check to see if you can use the item's existing holes. If not,



Painting furniture

you will have to fill the old holes with wood filler and drill new holes prior to painting.

WOOD

Unless you are using a piece of unfinished furniture, you will need to examine the piece for scratches, dust and other surface imperfections.

Lightly sand the entire piece to remove any surface contamination and/or old, flaking paint. Wipe off dust and other particles with a damp cloth or tack cloth and allow to dry.

METAL

Sand the entire piece with 320 grit or finer sandpaper so the paint will adhere.

Use naval jelly or coarse grit sandpaper to remove rust. Old, peeling paint should also be removed.

Wipe off dust and other particles with a tack cloth.

WICKER

Hose down wicker with luke-warm water, paying careful attention to corners and crevices.

Allow to dry thoroughly.

Operation

Test the Easy Spray Gun on a scrap piece of cardboard to determine if thinning is required. When sprayed, the coating should produce a very smooth finish, with tiny droplets visible around the edges of the spray pattern. If the spray sputters or sprays inconsistently, it may be too thick. If so follow the thinning directions, available where the paint was purchased. Once you have thinned the paint (if necessary) test spray to determine proper material and air flow adjustment, as well as the distance from the surface.

Operation (Con't)

Spraying Techniques

GETTING STARTED

Place the furniture or object on a dropcloth or in an area protected from any overspray damage. It's best if the piece can be hung so that all surfaces can be sprayed at the same time. If not let the coating on the exposed surfaces dry at least 24 hours before repositioning the piece and painting the previously unexposed areas.

PROPER HANDLING

The key to successful spray painting is proper handling of the spray gun. Hold the gun so the spray tip is perpendicular to the surface you are painting and about

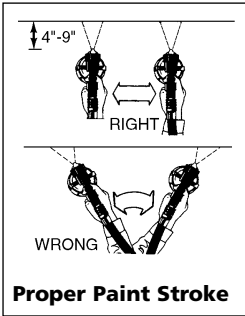

4" to 9" away (move closer for smaller patterns). Paint with a side-to-side motion, keeping the gun perpendicular to the surface. Bend your wrist slightly to keep the nozzle an even distance away from the surface as you move your arm back and forth.

Painting a Room

CROWN MOLDING

Begin with the crown molding. Since the walls will be painted later, you only need to shield against the ceiling. The size of the Campbell



Campbell Hausfeld Easy Shield

Hausfeld Easy Shield (HV7003) is wide enough to protect the corner area of ceilings where trim meets trim.

WINDOW TRIM AND DOOR FRAMES

With the gun settings the same as described in the crown molding section, do the window trim and door frames next. When spraying window trim, you can either invest time on the front end or add a little time to the spraying and clean up effort for a flawless job. If you choose the front end, you can protect the window glass by taping newspaper to the panes. This requires some added prep

Retaining Ring

Air Cap

Horizontal Pattern
Use up and down strokes

Vertical Pattern
Use right to left or left to right strokes

Round Pattern
Stroke in any direction

Pattern Selection/Uses

Adjusting the Material Flow

Adjusting the Air Flow

Operation (Con't)

time, but allows you to be a little sloppy during the painting portion, or turn the air flow and material down to make as small a pattern as you can. Any overspray can be removed with a razor blade or scraper. With this method, practice definitely makes perfect.

BASEBOARDS

For the baseboards, you only need to shield against the flooring. It is important to vacuum or sweep around the baseboards so that carper fibers and dust don't find their way into your paint job.

The most comfortable way to spray baseboards is the set the pattern control to the horizontal position and hold the gun on its side as you work your way around the baseboard.



Turn the gun so that the top is toward the adjoining wall when you are spraying corners. **CAUTION:** When cleaning the gun, pay special attention to the hollow screws under the check valve (shown in

Replacement Parts Diagram).

Holding gun sideways or upside down can allow small amounts of paint to clog the air passages.

WALLS

When you're ready to paint your walls, two coats of paint are recommended. Overlap each stroke by 1/2" to 1/3" use the Easy Shield to protect around the corners of your window trim and door frames.

ACCESSORIES

The Easy Spray Gun can be used with excellent results on furniture, shelves,

picture frames and other small items used to accessorize a room. While trim color is still in the gun, paint some of these items to give your room a polished, coordinated look.

PAINTING CABINET DOORS

Lay the removed cabinet doors flat on the floor or level surface or prop against a sturdy object in a dust-free environment. Be sure to protect surrounding areas from overspray. Begin by spraying any recessed grooves and edges. Start at one corner of the groove, spraying around the cabinet's perimeter at a distance of 6" to 8". After the grooves have been sprayed, paint the rest of the surface using the side-to-side method. Paint should dry for 24 hours before painting the reverse sides.



Spraying cabinet doors

Spraying cabinet doors can be quicker and use less space if you construct a spraying rack for this task. This needs to be nothing fancier than a frame of 2x4s and some metal hooks. Suspend the doors by the hooks leaving enough space to spray both sides and all edges.

PAINTING DRAWERS

Paint drawer fronts the same way you would paint cabinet doors. Be careful not paint any part of the drawer track or slide. This will prevent smooth operation.

Operation (Con't)

PAINTING WICKER

When painting wicker you will need to spray both vertically and horizontally to cover the surface. You may need to turn furniture upside down and repeat spraying to cover completely.



Painting Wicker

Cleaning & Maintenance

CAUTION

Make sure working area is well

ventilated when using solvents. Dispose of all materials properly in accordance with all local regulations.

1. Remove and set aside the material control knob, spring and needle. (Pull trigger and use wrench - refer to #'s 2 & 3 in **Needle/Nozzle Replacement** section - to help remove the needle).

NOTICE

Remove needle before removing

nozzle to prevent needle damage.

2. Unscrew and remove retaining ring, air cap, nozzle and air flow ring. Use supplied wrench to remove nozzle.
3. Place retaining ring, air cap, nozzle, air flow ring and the paint cup in a bucket or other suitable container. Soak in an appropriate solvent, or in soap and water if latex was used .
4. To clean the gun, pour solvent through material tube until the solution clears. Use brush to scrub material tube.

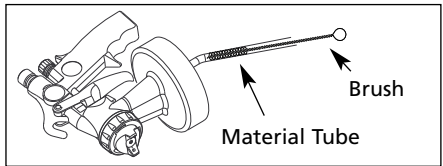
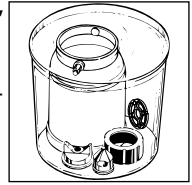

WARNING

Never spray undiluted solvent through gun.

5. Use air from turbine hose to dry components and passages.

NOTICE

Replace nozzle before replacing needle to prevent needle damage.

6. To reassemble, follow steps shown in **Needle/Nozzle Replacement** section.

Troubleshooting Chart

Symptom	Possible Cause(s)	Corrective Action
No material flow	<ol style="list-style-type: none"> 1. Clogged nozzle/air cap 2. Clogged cup pressure tube or fittings 3. Clogged gun 4. Clogged material tube 5. Cup seal leaking 	<ol style="list-style-type: none"> 1. Disassemble and clean 2. Disassemble and clean (a straight pin can be used to clean fittings) 3. Disassemble and clean 4. Disassemble and clean gun and check valve 5. Inspect cup seal, cup cap and clean or replace as necessary 6. Strain paint
	<ol style="list-style-type: none"> 6. Material not properly mixed or improperly filtered 	

Troubleshooting Chart (Continued)

Symptom	Possible Cause(s)	Corrective Action
Slow material flow	1. Material too thick	1. Clean material tube, gun and fittings then thin the material
	2. Improper material adjustment	2. Adjust material control knob
	3. Wrong needle/nozzle	3. Refer to material application chart for correct needle/nozzle
	4. Air filter clogged	4. Remove and replace air filter
	5. Material not properly mixed or improperly filtered	5. Strain paint
	6. Material too cold	6. Raise material temp. to 60°F (15°C)
Material leak	1. Cup or gun damaged	1. Check cup gun and replace damaged parts
	2. Loose packing	2. Adjust packing nut
	3. Worn or damaged packing	3. Remove and replace
	4. Worn or damaged cup seal	4. Remove and replace
	5. Loose cup fittings	5. Tighten
	6. Loose nozzle	6. Tighten
	7. Wrong needle/nozzle assembly	7. Refer to material application chart for correct needle/nozzle
	8. Damaged needle	8. Replace
	9. Loose material control knob	9. Properly adjust by turning clockwise
	10. Cup seal leaking	10. Clean and dry before use
Spray will not shut off	1. Dirty needle	1. Clean or replace needle
	2. Packing too tight	2. Adjust packing nut
	3. Loose material control knob	3. Tighten
	4. Missing spring	4. Install spring
Pulsating spray	1. Cup seal or check valve leaking	1. Disassemble and clean
	2. Packing improperly adjusted	2. Adjust packing nut or replace packing
	3. Loose fittings on cup or gun	3. Tighten
	4. Loose retaining ring	4. Tighten
	5. Loose nozzle	5. Tighten
	6. Damaged air flow ring	6. Replace
	7. Material not properly mixed or improperly filtered	7. Strain paint
Excessive over-spray	1. Material too thin	1. Check material viscosity (add non-thinned material)
	2. Excessive air flow	2. Adjust air flow
	3. Wrong needle/nozzle	3. Change needle/nozzle assembly
	4. Gun too far from work surface	4. Move gun closer to surface
	5. Spray blown by wind	5. Shelter area
	6. Excessive material flow	6. Adjust material flow control knob
	7. Material not properly mixed or improperly filtered	7. Strain paint
Spray not uniform (spitting)	1. Material too thick	1. Check material viscosity (Thin per instructions)
	2. Wrong needle/nozzle assembly	2. Change to proper needle/nozzle
	3. Cup seal leaking	3. Tighten cup, replace seal or check valve
	4. Loose packing	4. Adjust or replace packing
	5. Material not properly mixed or improperly filtered	5. Strain paint

Troubleshooting Chart (Continued)

Symptom	Possible Cause(s)	Corrective Action
Poor pattern	<ol style="list-style-type: none"> 1. Material buildup on nozzle or air cap 2. Worn nozzle/needle 3. Clogged air cap 4. Material not properly mixed or improperly filtered 	<ol style="list-style-type: none"> 1. Clean nozzle and air cap 2. Replace 3. Clean 4. Strain paint
Overheating	Clogged filter	Replace
Poor air flow	<ol style="list-style-type: none"> 1. Clogged filter 2. Air flow control improperly adjusted 	<ol style="list-style-type: none"> 1. Replace filter 2. Adjust air flow control
Spray tip clogs	<ol style="list-style-type: none"> 1. Improper material flow adjustment 2. Cup seal leaking 3. Wrong needle/nozzle 	<ol style="list-style-type: none"> 1. Adjust material control 2. Replace cup seal 3. Change to proper needle/nozzle

Troubleshooting Chart - Finish Quality

Symptom	Possible Cause(s)	Corrective Action
Orange Peel (Rough rolling appearance similar to an actual orange peeling)	<ol style="list-style-type: none"> 1. Material drying too fast 2. Gun too far from surface 3. Material too thick 	<ol style="list-style-type: none"> 1. Use a slower solvent or add a retarding agent 2. Move gun closer to surface 3. Thin material per thinning instructions
Runs and sags	<ol style="list-style-type: none"> 1. Material too thin 2. Moving gun too slow 3. Excessive material flow 4. Gun too close to surface 	<ol style="list-style-type: none"> 1. Add material to increase thickness 2. Move gun more quickly 3. Turn material control knob clockwise to reduce flow 4. Move gun further from surface
Pin-holing and solvent pops	<ol style="list-style-type: none"> 1. Trapped solvents 2. Pigment settling 3. System contamination 	<ol style="list-style-type: none"> 1. Apply material in lighter coats allowing solvents time to evaporate 2. Possible bad material 3. Thoroughly clean all parts
Fish eye	Possible silicone contamination	Use solvent to clean all parts and work surfaces
Blistering	<ol style="list-style-type: none"> 1. Moisture in/on surface 2. Incompatible top coats or under-coats 	<ol style="list-style-type: none"> 1. Dry surface 2. Make sure coatings are compatible
Lumpy, coarse surface	Dirt on surface	Thoroughly clean surface
Mottled surface finish	<ol style="list-style-type: none"> 1. Too much thinner 2. Poor spray technique 	<ol style="list-style-type: none"> 1. Reduce thinner 2. Refer to "Operation" for spraying instructions

For Replacement Parts, Call 1-800-626-4401

Please provide following information:

- Model number
- Serial number (if any)
- Part descriptions and number as shown in parts list

Address parts correspondence to:

Campbell Hausfeld
 Attn: Parts Department
 100 Production Drive
 Harrison, OH 45030 U.S.A.

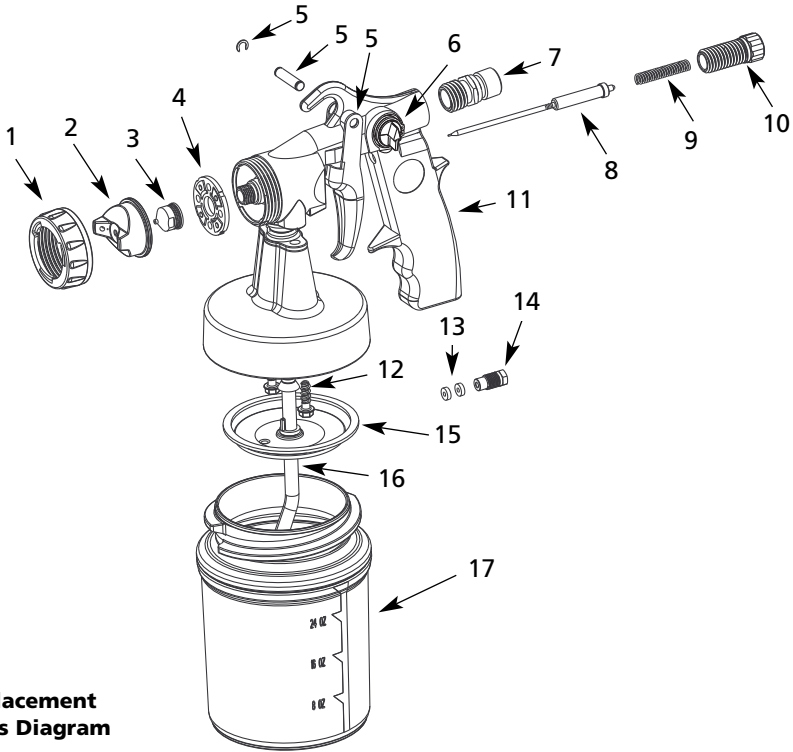

**Replacement
Parts Diagram**

Ref No.	Description	Part Number	Qty
1	Retaining ring	HV000901AV	1
2	Aircap	HV000801AV	1
3	Nozzle (all-purpose)	HV003000AV	1
4	Airflow ring	HV001201AV	1
5	Trigger assembly	SK206101AJ	1
6	Air flow control assembly	SK206200AJ	1
7	Male quick connect	HV003500AV	1
8	Needle (all-purpose)	HV009200AV	1
9	Spring	HV002900AV	1
10	Material control knob	HV008401AV	1

Ref No.	Description	Part Number	Qty
11	Quick turn gun body (incl. #'s 5, 6, 7, 12-14)	HV011504SV	1
12	Air flow screws	MJ106300AV	2
13	Packing (incl. #2)	HV002800SV	2
14	Packing nut	HV009201AV	1
15	Check valve	HV008300AV	1
16	Material tube	HV007100AV	1
17	Plastic canister	HV007002AV	1
	Metal canister	HV007500AV	1
★	Canister seal kit (includes 3 seals) Not shown	SK206401AJ	1

Limited Warranty

1. **DURATION:** From the date of purchase by the original purchaser as follows: Standard Duty Paint Application Systems and all Paint Application Accessories - 1 year, Serious Duty Paint Application Systems - 3 years, Extreme Duty Paint Application Systems - 5 years.
2. **WHO GIVES THIS WARRANTY (WARRANTOR):** Campbell Hausfeld/A Scott Fetzer Company, 100 Production Drive, Harrison, Ohio, 45030, Telephone: 1-800-626-4401.
3. **WHO RECEIVES THIS WARRANTY (PURCHASER):** The original purchaser (other than for purposes of resale or rental) of the Campbell Hausfeld Product.
4. **WHAT PRODUCTS ARE COVERED BY THIS WARRANTY:** All non-compressor driven paint application systems, HVLP spraying systems, and paint application accessories supplied or manufactured by the Warrantor.
5. **WHAT IS COVERED UNDER THIS WARRANTY:** Defects in material and workmanship which occur within the duration of the warranty period. Warrantor will also cover normal wear items for a period of thirty days from the date of original purchase against defects in material and workmanship. These wear items are: HVLP-filters, motor brushes, gun packing, gun canister seal, gun check valve and gun air flow ring; Airless-inlet valve, outlet valve, gun valve, filters, tips, all seals and o-rings.
6. **WHAT IS NOT COVERED UNDER THIS WARRANTY:**
 - A. Implied warranties, including those of merchantability and FITNESS FOR A PARTICULAR PURPOSE ARE LIMITED FROM THE DATE OF ORIGINAL PURCHASE AS STATED IN THE DURATION. If standard duty product is used for commercial or industrial purposes, the warranty will apply for ninety (90) days from the date of original purchase. If product is used for rental purposes, the warranty will apply for ninety (90) days from the date of original purchase. Some states do not allow limitation on how long an implied warranty lasts, so the above limitations may not apply to you.
 - B. ANY INCIDENTAL, INDIRECT, OR CONSEQUENTIAL LOSS, DAMAGE, OR EXPENSE THAT MAY RESULT FROM ANY DEFECT, FAILURE, OR MALFUNCTION OF THE CAMPBELL HAUSFELD PRODUCT. Some states do not allow the exclusion or limitation of incidental or consequential damages, so the above limitation or exclusion may not apply to you.
 - C. Any failure that results from an accident, purchaser's abuse, neglect or failure to operate products in accordance with instructions provided in the owner's manual(s) supplied with product. Accident, purchaser's abuse, neglect or failure to operate products in accordance with instructions shall also include the removal or alteration of any safety devices. If such safety devices are removed or altered, this warranty is void.
 - D. Normal adjustments which are explained in the owner's manual(s) provided with the product.
 - E. Items or services that are normally required to maintain the product: HVLP-filters, motor brushes, gun packing, gun canister seal, gun check valve and gun air flow ring; Airless-inlet valve, outlet valve, gun valve, filters, tips, all seals and o-rings., or any other expendable part not specifically listed, will only be covered for thirty days from date of original purchase.
7. **RESPONSIBILITIES OF WARRANTOR UNDER THIS WARRANTY:** Repair or replace, at Warrantor's option, products or components which are defective, have malfunctioned and/or failed to conform within duration of the warranty period.
8. **RESPONSIBILITIES OF PURCHASER UNDER THIS WARRANTY:**
 - A. Provide dated proof of purchase and maintenance records.
 - B. Deliver or ship the Campbell Hausfeld product or component to the nearest Campbell Hausfeld Authorized Service Center. Freight costs, if any, must be borne by the purchaser.
 - C. Use reasonable care in the operation and maintenance of the products as described in the owner's manual(s).
9. **WHEN WARRANTOR WILL PERFORM REPAIR OR REPLACEMENT UNDER THIS WARRANTY:**
 - A. Repair or replacement will be scheduled and serviced according to the normal work flow at the servicing location, and depending on the availability of replacement parts.
 - B. If the purchaser does not receive satisfactory results from the Authorized Service Center, the purchaser should contact Campbell Hausfeld (see paragraph 2)

This Limited Warranty applies in the U.S. and Canada only and gives you specific legal rights. You may also have other rights which vary from state to state, or country to country.

S'il vous plaît lire et conserver ces instructions. Lire attentivement avant de monter, installer, utiliser ou de procéder à l'entretien du produit décrit. Se protéger ainsi que les autres en observant toutes les instructions de sécurité, sinon, il y a risque de blessures et/ou dégâts matériels!

BREVET POUR LES É-U 6,036, 109; 6,068,203

**Conseils
Ci-Inclus!**



Pistolets Easy Spray

Table Des Matières

Description	1
Généralités Sur La Sécurité	1-2
Montage	2-3
Remplacement D'Aiguille/Buse	4
Préparation	5
Opération	5-8
Nettoyage Et Entretien	8
Guide De Dépannage	8-10
Pièces De Rechange	11
Garantie	12

Description

Les pulvérisateurs de peinture haut volume, basse pression (HVLP) sont conçus pour fournir un fini fin avec un niveau bas de surpulvérisation. Le pulvérisateur est conçu pour l'application de plusieurs types d'acryliques, de teintures, de bouche-pores, de produits latex et d'apprêts. Ce modèle peut être utilisé pour la peinture des armoires, des meubles, des machines, de l'équipement, des murs et des moulures. Ces pulvérisateurs ne sont pas recommandés pour les couches de finition d'automobiles. Ce modèle portable est un alternatif idéal aux pistolets pulvérisateurs traditionnels. L'efficacité supérieure de transfert du modèle Easy Spray fournit un résultat professionnel avec moins de gaspillage et de contamination à l'environnement que les autres systèmes de peinture traditionnels.

Déballage

Lors du déballage du pulvérisateur, l'examiner soigneusement pour rechercher

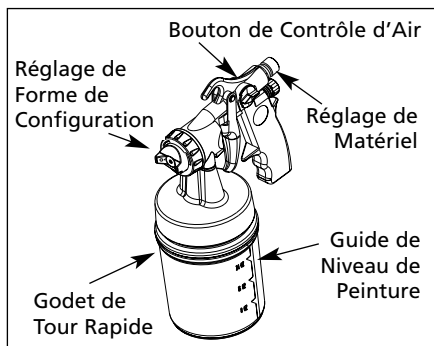

Caractéristiques du Pistolet Vaporisateur

toute trace de dommage susceptible de s'être produit en cours de transport. Vérifier le serrage de tous raccords, boulons, etc., avant de mettre le pulvérisateur en service. Chaque pulvérisateur a été éprouvé avant d'être expédié.

REMARQUE: L'écrou de presse-étoupe pourrait nécessiter un réglage additionnel à cause de la relaxation du matériel d'emballage pendant l'expédition.

Le fluide utilisé pendant la mise à l'essai du pulvérisateur a été purgé, mais il vas en rester dans le pistolet. Rincer ce fluide du pistolet pulvérisateur afin d'éviter la contamination de l'enduit. Utiliser un solvant compatible avec l'enduit.

Généralités Sur La Sécurité

⚠ DANGER

**Danger
indique**

une situation hasardeuse imminente qui, si pas évitée, RÉSULTERA en perte de vie ou en blessures graves.