

CAMPBELL HAUSFELD

OPERATING INSTRUCTION MANUAL

SANDBLASTING KITS

MODELS AT125102AJ, AT121002AJ, AND
AT121102AJ

READ CAREFULLY BEFORE ATTEMPTING TO ASSEMBLE, INSTALL, OPERATE OR MAINTAIN THE PRODUCT DESCRIBED. PROTECT YOURSELF AND OTHERS BY OBSERVING ALL SAFETY INFORMATION. FAILURE TO COMPLY WITH INSTRUCTIONS COULD RESULT IN PERSONAL INJURY AND/OR PROPERTY DAMAGE!

RETAIN INSTRUCTIONS FOR FUTURE REFERENCE.

Description

Campbell Hausfeld sandblasting equipment is designed for cleaning and removing rust, scale, paint, grime and dirt for stripping, polishing and etching projects. This equipment can be used with sand, abrasive powders, or water and other liquids.

Unpacking

After unpacking the sandblasting kit, carefully inspect for any damage that may have occurred during transit. Check for loose, missing or damaged parts.

General Safety Information

1. Read this instruction manual before installing this device to the compressor pump.
2. Safety glasses or face shield, gloves and a respirator must be worn during operation. Always work in a well ventilated area.

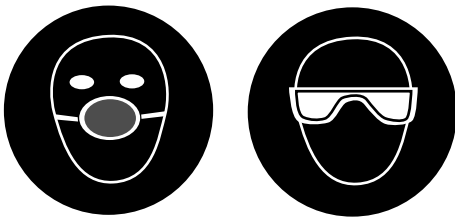

Figure 1

3. During operation, do not expose the hands or skin directly in the line of the blast nozzle.
4. After installation, inspect to make sure all components seal properly.
5. Keep children away at all times. All visitors must be kept a safe distance and wear safety glasses, gloves and a respirator.
6. Do not exceed the maximum operating pressure of the sandblasting equipment (125 PSI).

⚠ WARNING ⚠

DISCONNECT THE SANDBLASTER FROM THE AIR SUPPLY BEFORE CHANGING ACCESSORIES OR ATTEMPTING TO INSTALL, SERVICE, RELOCATE OR PERFORM ANY MAINTENANCE.

Copyright 1993, Campbell Hausfeld/Scott Fetzer Company

7. Check hoses and air lines for weak or worn condition before each use. Make sure all connections are secure before use.

⚠ WARNING ⚠

DO NOT POINT THE SANDBLAST GUN AT ANYONE OR OBJECTS OTHER THAN THE INTENDED WORK OBJECT.

8. Do not depress the trigger when connecting the air supply hose.

⚠ DANGER

DO NOT WORK AROUND OILY RAGS OR FLAMMABLE LIQUIDS. SAND STRIKING METAL CAN CAUSE A SPARK AND CREATE A FIRE OR EXPLOSION.



Figure 2

⚠ WARNING ⚠

DO NOT SPRAY ACIDS OR CAUSTICS.



Figure 3

Specifications

MODEL	NOZZLE	HOPPER CAPACITY	MAXIMUM PSI	HP REQUIRED	MINIMUM CFM
AT125102AJ	Ceramic	30 lbs	125	1 or more	2.2 @ 40 PSI
AT121002AJ	Ceramic	60 lbs	125	2 or more	2.2 @ 40 PSI
AT121102AJ	Ceramic	120 lbs	125	2 or more	2.2 @ 40 PSI

Assembly

HOSE CONNECT ASSEMBLY FOR MODEL AT125102AJ - 30 LBS

1. Attach the material hose to the hose connector. Attach the opposite end of the material hose to the gun (See Figure 4).

NOTE: **DO NOT** cover the hole in the hose connector for dry blasting. For use with liquids, slip the material hose fully on the hose connector covering the hole.

2. Attach the air compressor hose to the opening at the bottom of the gun handle. An optional 1/4" NPT quick connector (MP2468) and coupler (MP2883) can be used to attach the hose to the gun.

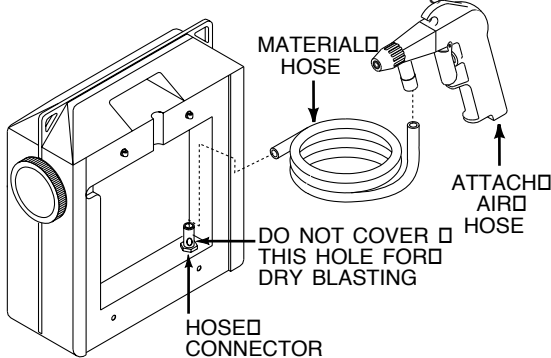

Figure 4 – Model AT125102AJ - 30 LBS

HOSE CONNECT ASSEMBLY FOR MODEL AT121002AJ - 60 LBS

1. Attach the hose connector to the hopper using the conduit nut.
2. Attach the material hose to the hose connector. Attach the opposite end of the material hose to the gun (See Figure 5).

NOTE: **DO NOT** cover the hole in the hose connector for dry blasting. For use with liquids, slip the material hose fully on the hose connector covering the hole.

3. Attach the air compressor hose to the opening at the bottom of the gun handle. An optional 1/4" NPT quick connector (MP2468) and coupler (MP2883) can be used to attach the hose to the gun.

HOPPER AND HOSE CONNECT ASSEMBLY FOR MODEL AT121102AJ - 120 LBS

1. Slide the wheel onto the axle and lightly hammer on the wheel cap. Make sure the protruding hub on the wheel is facing the hopper (See Figure 6). Repeat for the opposite side.
2. Attach the hose connector to the hopper using the conduit nut.

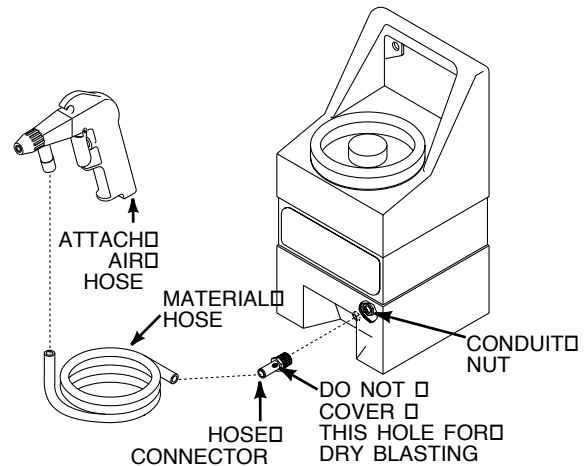

Figure 5 – Model AT121002AJ - 60 LBS

3. Attach the material hose to the hose connector. Attach the opposite end of the material hose to the gun (See Figure 6).

NOTE: **DO NOT** cover the hole in the hose connector for dry blasting. For use with liquids, slip the material hose fully on the hose connector covering the hole.

4. Attach the air compressor hose to the opening at the bottom of the gun handle. An optional 1/4" NPT quick connector (MP2468) and coupler (MP2883) can be used to attach the hose to the gun.

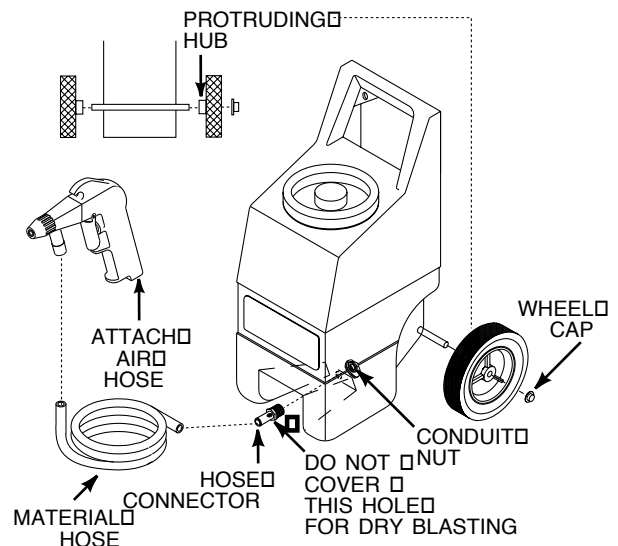

Figure 6 – Model AT121102AJ - 120 LBS

Installation

It is recommended that sandblasting equipment be used with commonly available sandblast cabinets. However, a temporary sandblasting booth can also be used.

MAKING A TEMPORARY SANDBLAST BOOTH

To make a temporary sandblast booth, refer to Figure 7 and follow the outlined procedures below.

Material needed:

- 1 roll of 3" plastic tape
- 1 large corrugated box
- 4 square feet of plexiglass
- 1/4 yard of old cloth

1. Cut a rectangular hole out of one side on the box to serve as a window opening. Leave a least a two inch border around the cutoff for strength.
2. Cut the plexiglass two inches wider than the cutoff dimensions. This will be the top of the booth.
3. Cut two five inch round holes in one or two of the other sides of the box for arm holes.
4. Cut two pieces of cloth approximately eight inches wide to act as a curtain for the arm holes. Tape the top of the cloth pieces to the inside of the box so that the cloth hangs over each hole.
5. Cut a 1-1/2 inch hole in the corner of the flaps on the open end of the box for the air and material hoses.
6. (OPTIONAL) Cut a small hole in the unopened end of the box for inserting a hole from a shop vacuum. This will aid in clearing dust and collecting sand for reuse.

To use the sandblasting booth, put the booth on a work bench with an overhead light. Put the object to be sandblasted and the sandblast gun into the box. Tape the open end shut.

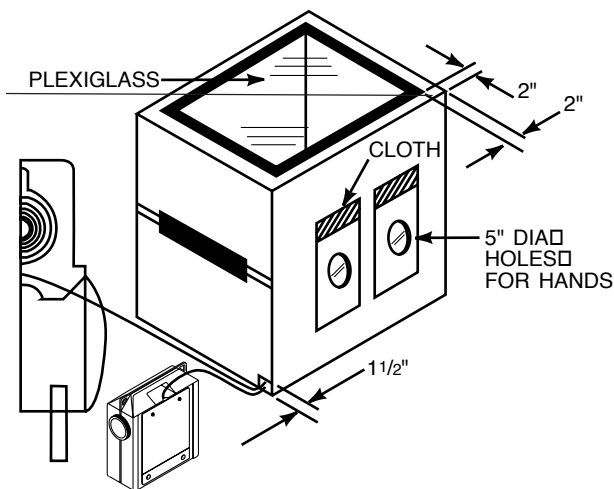

Figure 7

Operation

1. Always wear a safety shield or safety glasses, gloves and a respirator when sandblasting.
2. Locate the compressor as far away as possible from the sandblasting area to minimize the dust in the compressor intake.
3. The higher the air pressure (maximum 125 PSI), and the closer to the work, the quicker the job will be done.
4. Use a large grit abrasive to remove material and use a small grit to smooth surfaces.
5. Always trial test the sandblaster to make sure the job is done without damage by testing on a hidden surface.
6. Always filter (screen) the abrasive material to remove any caked material and prevent clogging.
7. Use a compressor that can supply enough air (See Specifications). A compressor too small will cause air pressure to drop and the sandblaster will not operate satisfactorily.
8. Do not try to spray heavy liquids.
9. When spraying devices such as carburetors, stuff rags or paper into all openings to prevent internal damage.
10. Use the lowest effective pressure on soft surfaces to prevent pitting the surface.
11. Whenever the nozzle is removed and replaced, use a brush to clean the threads and replace the o-ring.
12. Soap and water can be used for cleaning purposes for automobiles, lawn chairs, etc.

MOISTURE IN COMPRESSED AIR

Moisture in compressed air will form into droplets as the air comes from the compressor pump. When humidity is high or when a compressor is in continuous use for an extended period of time, moisture will collect in the tank. When using a sandblast gun, this water will be carried from the tank through the hose and out of the gun as droplets mixed with the material being sprayed.

IMPORTANT: THIS CONDENSATION WILL CAKE THE SAND AND CLOG THE SANDBLASTING GUN. A CLOGGED GUN WILL NOT OPERATE.

A compressed air dryer and/or air line filter will help eliminate this moisture (MP2121)

Operation

TYPE OF ABRASIVE (SIEVE/SIZE)	APPLICATION
Sand (20-40)	General purpose use. Removing light rust and paint from metal, wood or other surfaces; wood finishing; metal cleaning; glass and stone etching; hole drilling in glass; brick or cement block cleaning; brass and silver cleaning; light brick cleaning; exterior automotive parts cleaning; light stone and cement removal and water deposit removal.
Sand (50-100)	Use for a fine polish finish or antique wood finish, brass and silver polishing, automotive parts cleaning and polishing, sheet metal surface polishing, and fine glass etching.
Aluminum Oxide	Heavy rust removal and rough surface paint removal
Corn Cob Meal	Wood cleaning (fine)
Walnut or Pecan Shells (Ground)	Wood cleaning (coarse)

NOTE: Abrasive media that has not been cleaned and screened should be avoided, because the media could contain material that will clog the gun.

Limited Warranty

1. **DURATION:** One year from the date of purchase by the original purchaser.
2. **WHO GIVES THIS WARRANTY (WARRANTOR):**

Campbell Hausfeld
The Scott Fetzer Company
100 Production Drive
Harrison, Ohio 45030
Telephone: (513) 367-4811

3. **WHO RECEIVES THIS WARRANTY (PURCHASER):** The original purchaser (other than for purposes of resale) of the Campbell Hausfeld product.
4. **WHAT PRODUCTS ARE COVERED BY THIS WARRANTY:** Any Campbell Hausfeld portable air compressor, air tool or supplementary air accessory supplied or manufactured by Warrantor.

5. **WHAT IS COVERED UNDER THIS WARRANTY:** Defects on material and workmanship which occur within the duration of the warranty period.

6. **WHAT IS NOT COVERED UNDER THIS WARRANTY:**

A. Implied warranties, including those of merchantability and FITNESS FOR A PARTICULAR PURPOSE ARE LIMITED TO ONE YEAR FROM THE DATE OF ORIGINAL PURCHASE. Some states do not allow limitations on how long an implied warranty lasts, so the above limitations may not apply to you.

B. ANY INCIDENTAL, INDIRECT, OR CONSEQUENTIAL LOSS, DAMAGE, OR EXPENSE THAT MAY RESULT FROM ANY DEFECT, FAILURE, OR MALFUNCTION OF THE CAMPBELL HAUSFELD PRODUCT. Some states do not allow the exclusion or limitation of incidental or consequential damages, so the above limitation or exclusion may not apply to you.

C. Any failure that results from an accident, purchaser's abuse, neglect or failure to operate products in accordance with instructions provided in the owner's manual(s) supplied with product.

D. Normal adjustments which are explained in the owner's manual(s) provided with the product.

E. Items or service that are normally required to maintain the product, i.e. lubricants.

7. **RESPONSIBILITIES OF WARRANTOR UNDER THIS WARRANTY:** Repair or replace, at Warrantor's option, products or components which have failed within duration of the warranty period.

8. **RESPONSIBILITIES OF PURCHASER UNDER THIS WARRANTY:**

A. Deliver or ship the Campbell Hausfeld product or component to the nearest Campbell Hausfeld Authorized Service Center. Freight costs, if any, must be borne by the purchaser.

B. Use reasonable care in the operation and maintenance of the products as described in the owner's manual(s).

9. **WHEN WARRANTOR WILL PERFORM REPAIR OR REPLACEMENT UNDER THIS WARRANTY:**

A. Repair or replacement will be scheduled and serviced according to the normal work flow at the servicing location, and depending on the availability of replacement parts.

B. If the purchaser does not receive satisfactory results from the Authorized Service Center, the purchaser should contact the Campbell Hausfeld Product Service Department (see paragraph 2).

This Limited Warranty gives you specific legal rights and you may also have other rights which vary from state to state.

Suggested Uses

TYPE OF ABRASIVE (SIEVE/SIZE)	APPLICATION	DISTANCE FROM WORK	PSI	SUGGESTIONS
Sand (30-50) Glass Beads	Etching and Drilling Holes in Glass	1-4"	40-90	Move gun back and forth over the template in a brushing manner. Blast at a 90° angle. For fine polishing, use glass beads for the abrasive. For drilling holes, use 30 sieve sand
Sand (40) Ground Walnut Shells	Antiquing or Weathering Wood	2-6"	40-90	Use brushing strokes and watch the abrasion rate carefully. Soft wood will wear faster than hardwood. Smaller grit sizes give a smoother finish. Start with low pressure and gradually build up pressure. Blast at a 45° angle
Sand (50-100) Glass Beads Ground Walnut Shells	Wood Sanding and Refinishing Furniture	1-6"	40-70	Use brushing strokes and watch the abrasion rate carefully. Use walnut shells for coarse finishing and glass beads or fine sand for fine finishing. Blast at a 45° angle
Sand (20-40)	Cleaning Barbecue Grills and Iron Pots	1-4"	50-125	Use larger grit sand on a hidden area. If the base material is being damaged, use a smaller grit. Blast at a 80-90° angle
Sand (20-40) Aluminum Oxide	Cleaning Automotive Parts	1-4"	40-80	Be sure to mask any glass or painted surface that could be accidentally damaged. Blast at a 80-90° angle
Sand (20-40)	Cleaning and Stripping Masonry	1-4"	50-125	Use a heavy grit sand with a sweeping overlapping stroke. Blast at a 80-90° angle
Ground Pecan or Walnut Shells & Corn Cob Meal	Cleaning or Preparing for Paint	1-6"	40-125	Use brushing strokes and watch the abrasion rate carefully. Soft wood will wear faster than hard wood. Smaller grit sizes give a smoother finish. Start with low pressure and gradually build up pressure. Blast at a 45-60° angle
Sand (20-50) Aluminum Oxide (50-80)	Cleaning, Stripping Outdoor Equipment	1-3"	50-125	Remove flaking paint first with wire brush, then sandblast with a heavy grit abrasive. Multiple layers of old paint should be scraped first. Prime immediately following sandblasting to prevent corrosion. Blast at a 45-60° angle

Technical Service

For information regarding the operation or repair of this product, please call 1-800-543-6400 between 8 a.m. and noon or between 1 p.m. and 5 p.m. (EST), Monday through Friday for assistance. If you are calling from Ohio or outside the continental United States, please call collect, 1-513-367-1182.

Please provide following information:

- Model Number
- Serial Number (if any)
- Part Description and Number as shown in Parts List.

Address parts correspondence to:

Campbell Hausfeld
100 Production Drive
Harrison, Ohio 45030

Troubleshooting Chart

SYMPTOM	POSSIBLE CAUSE(S)	CORRECTIVE ACTION
Low or no air pressure	<ol style="list-style-type: none"> 1. Regulator set incorrectly 2. Pinched hose 3. Dirty compressor filter 	<ol style="list-style-type: none"> 1. Reset regulator 2. Straighten hose 3. Clean or replace filter
Material not blasting from gun	Clogged material hose	Lower the pressure below 40 PSI. Firmly hold the gun tip flat against the ground and pull the trigger to force the material back out of the material hose
Clogged gun	<ol style="list-style-type: none"> 1. Damp or heavy material 2. Water in air supply 	<ol style="list-style-type: none"> 1. Replace with dry abrasive.(Damp material can be dried and reused). 2. Drain air tank and install air filter. See "Moisture in Compressed Air" box
Gun will not shut off – trigger stuck	Damaged o-rings	Remove and replace o-rings
Sputtering – low vacuum	<ol style="list-style-type: none"> 1. Worn jet and/or nozzle 2. Abrasive buildup around jet/nozzle 	<ol style="list-style-type: none"> 1. Replace jet and/or nozzle 2. Remove nozzle and jet and clean. Make sure the threads are clean before replacing
Sputtering – air/abrasive leaks at nozzle/jet area	<ol style="list-style-type: none"> 1. Loose nozzle or jet 2. Damaged o-ring 	<ol style="list-style-type: none"> 1. Tighten nozzle or jet 2. Replace o-ring
Sputtering – vacuum leak	<ol style="list-style-type: none"> 1. Loose material hose 2. Damaged o-ring 	<ol style="list-style-type: none"> 1. Tighten material hose 2. Replace o-ring
Sputtering – particle clogging	Hose connector hole is covered	Uncover hose connector hole

Service Notes

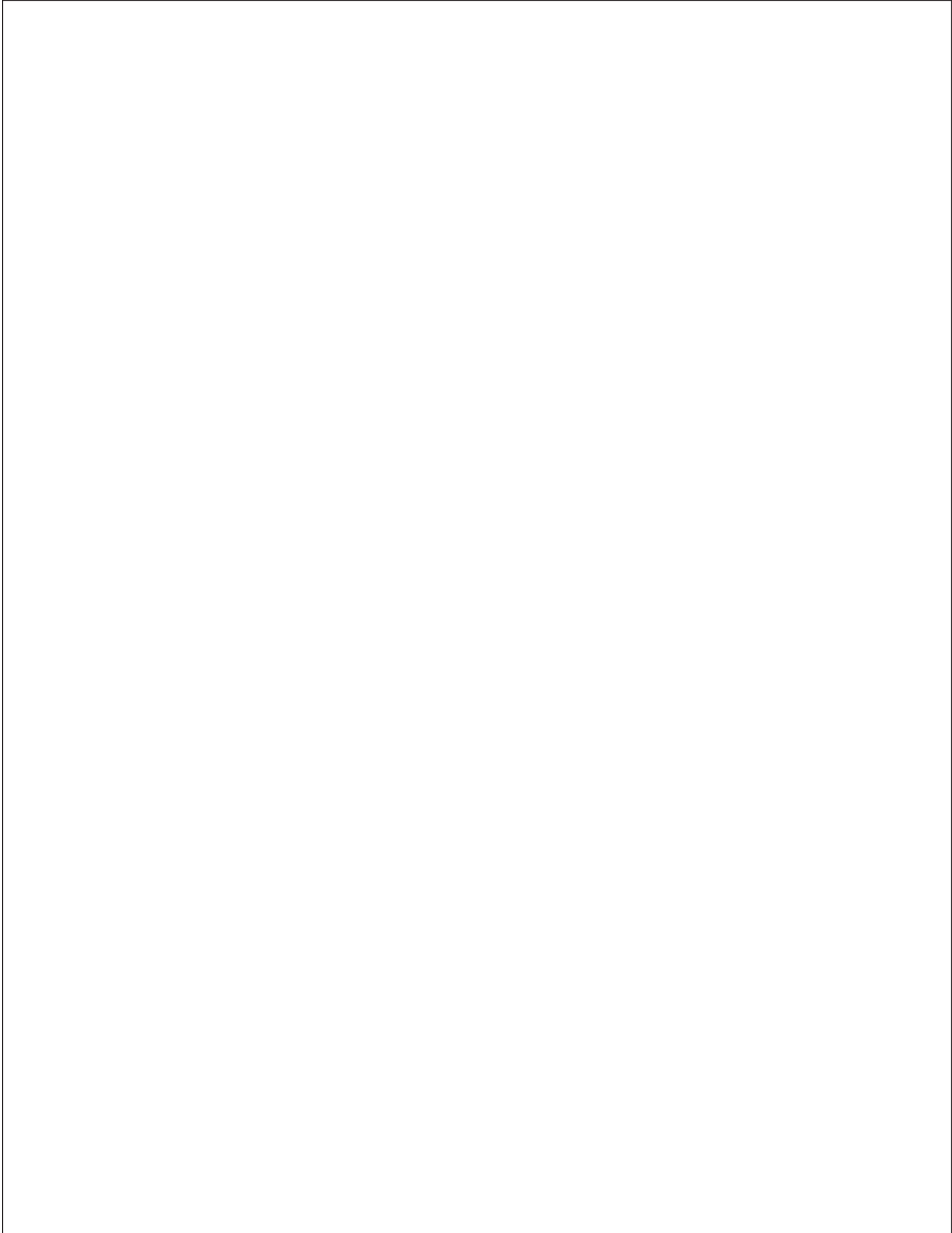

Service Notes

A large empty rectangular box intended for service notes.